

## THERMOCROMEX OVER FRAME & SHEATHING EXPANSION JOINT AT CASING BEAD OR FOUNDATION SCREED

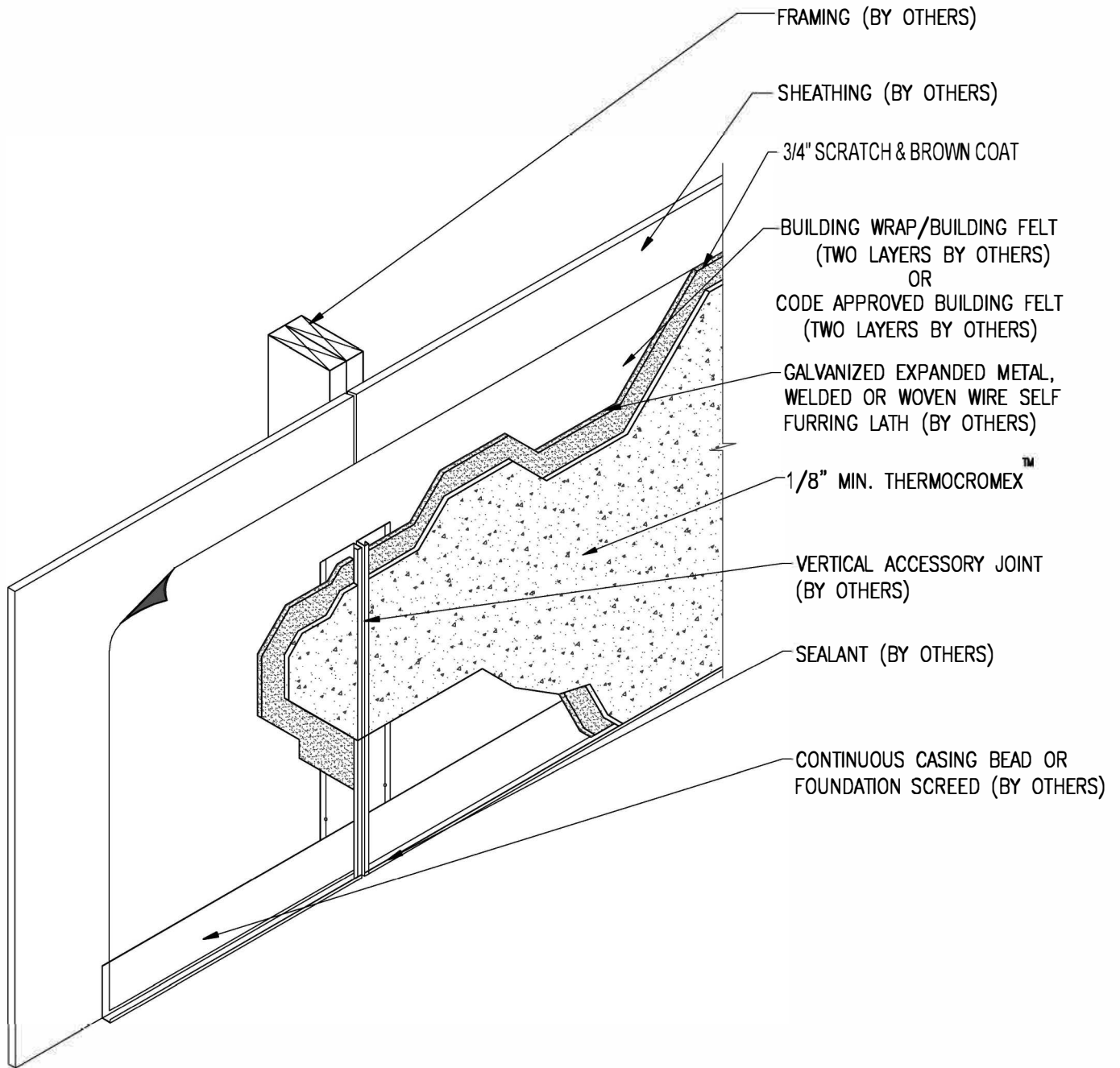

**SCALE = 1" = 1'-0"**